

Contents

Symbols, safety	2
General safety information	2
Correct use	3
Improper use	3
Operating parameters	4
Assembly	5
Connecting the Drive Set GSF 8 40 R10	8
Maintenance	9

Symbols, safety



Important, safety information, recommendation



Maintenance

General safety information

The details and information in the installation guide are provided for the purposes of describing the product and its assembly only. The information does not discharge the user from the obligation to carry out his own assessments and checks. It is important to bear in mind that our products are subject to a natural process of wear and ageing. These notes contain important information that will enable you to use the product safely and appropriately. When sold, rented out or otherwise passed on to another party, this product must be handed over with the installation guide.

When installing, operating and maintaining Linear Unit GSF 8 40 R10, it is important to ensure that all moving elements are secured so that they cannot be switched on and moved unintentionally. Rotating and moving parts can cause serious injury! You must therefore read and follow the safety instructions set out below.

- All work on and with Linear Unit GSF 8 40 R10 must be performed with "safety first" in mind.
- Always switch off the drive assembly before you start working on Linear Unit GSF 8 40 R10
- Ensure the drive unit cannot be switched on unintentionally, e.g. by affixing warning notices at the activation point or by removing the fuse from the power supply.

- Do not place your hand within the operating range of moving parts in Linear Unit GSF 8 40 R10 when the unit is still switched on.
- Fit guards and covers so that the moving parts of Linear Unit GSF 8 40 R10 cannot be touched unintentionally.
- Observe the regulations pertaining to accident prevention and environmental protection that apply in the country and place of work where the product is being used.
- Use only item products that are in perfect working order.
- Failure to use original spare parts will invalidate the product warranty!
- Check the product for obvious defects.
- Use the product only within the performance range described in the technical data.
- Ensure that all the safety equipment associated with the product is present, properly installed and in full working order.
- Do not alter the position of safety equipment, circumvent it or render it ineffective.

Linear Unit GSF 8 40 R10, as described here, corresponds to the state of the art and takes into account the general principles of safety applicable at the time this installation guide was published. Nevertheless, failure to observe the safety instructions and warning notices in this installation guide may result in personal injury and damage to property.

We will assume no liability for any resulting damage or injury. We reserve the right to make technical changes that represent technical advances. Keep these installation notes in a place where they can be easily accessed by all users. Observe the directions contained in the main user guide for the completed machine.

The general safety information applies to the entire lifecycle of the partly completed machine.

1. During transportation

Observe the handling instructions on the packaging. Until it is installed, the product must be stored in its original packaging, protected from moisture and damage. Ensure that moving parts are secured when in transit and cannot cause any damage.

2. During installation

Always deactivate the power to the relevant system part and ensure it is not live before installing the product and/or plugging it in or unplugging it. Ensure the system cannot be switched back on. Lay cables and lines in such a way that they cannot be damaged and do not represent a trip hazard. Avoid areas that pose slip, trip and fall hazards.

3. During start-up

Allow the product to acclimatise for a few hours before starting it up. Ensure that the partly completed machine is securely and safely integrated into the completed machine. Only start up a product that has been installed in full.

4. During operation

Ensure that only persons who have been authorised by the operator have access to the immediate operating environment of the system. This also applies when the system is not in operation. It must not be possible to actuate moving parts unintentionally. During emergencies, malfunctions or other irregularities, deactivate the system and ensure that it cannot be switched back on. Prevent the possibility of persons becoming trapped in the system's hazard zone.

5. During cleaning

Close all openings with suitable protective equipment to ensure that cleaning agents cannot penetrate the system. Do not use aggressive cleaning substances. Do not use a high-pressure cleaner when cleaning the system.

6. During maintenance and servicing work

Carry out the prescribed maintenance work at the intervals stipulated in the user guide. Ensure that no line links, connections or components are removed while the system is live and under pressure. Ensure the system cannot be switched back on.

7. During disposal

Dispose of the product in accordance with the national and international regulations that apply in your country.

Correct use

Linear Unit GSF 8 40 R10 is a partly completed machine as defined in the Machinery Directive (2006/42/EC). Linear Unit GSF 8 40 R10 must only be used in accordance with the technical data and safety requirements set out in this document. Internal company requirements and the regulations that apply in the country where the product is being used must be observed. You must not make any design modifications to Linear Unit KRF GSF 8 40 R10 yourself. We will assume no liability for any resulting damage or injury. You may only install, operate and maintain Linear Unit GSF 8 40 R10 if:

- Linear Unit GSF 8 40 R10 has been integrated properly and safely into the completed machine,
- You have carefully read and understood the installation guide,
- You are appropriately qualified,

- You are authorised to do so by your company,
- You are using only original equipment from the manufacturer.

Unsafe or inappropriate use of Linear Unit GSF 8 40 R10 runs a risk of serious injury through crushing and cuts.

Improper use

Improper use is defined as any use of the product for purposes other than those authorised in the installation guide and under the definition of correct use. We will assume no liability for any resulting damage or injury.

Operating parameters

Linear Unit GSF 8 40 R10 is constructed from Line 8 profiles that have been cut to size and various assemblies. Before starting assembly work, it is important to check that all parts are present.

Accessories:

0.0.654.21	Timing-Belt Reverse Unit GSF 8 40 R10
0.0.654.22	Timing-Belt Reverse Unit GSF 8 40 R10
0.0.654.23	Drive Set GSF 8 40
0.0.654.24	Slide Set GSF 8 80x40

⚠ The safety distance S is a reserve distance to accommodate tolerances and slide overtravel under high loads and accelerations at the reversal point. It must be factored into the equation depending on the capabilities of the drive and control system, but in any event should not be smaller than 27.5 mm!

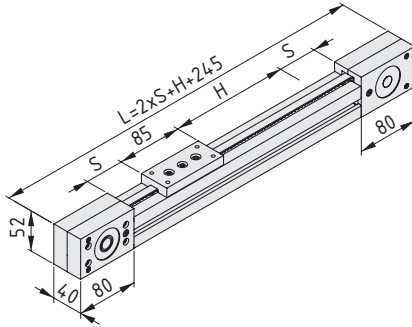

Linear Unit GSF 8 40 R10



$L_{min} = 300 \text{ mm}$
 $S_{min} = 27.5 \text{ mm}$
 $H_{max} = 3860 \text{ mm}$
 $m_1 = 1.3 \text{ kg}$
 $m_2 = 1.85 \text{ g/mm}$
 Repeat accuracy = $\pm 0.5 \text{ mm}$
 Installation guide

1 set

0.0.655.98

Parameters, geometry

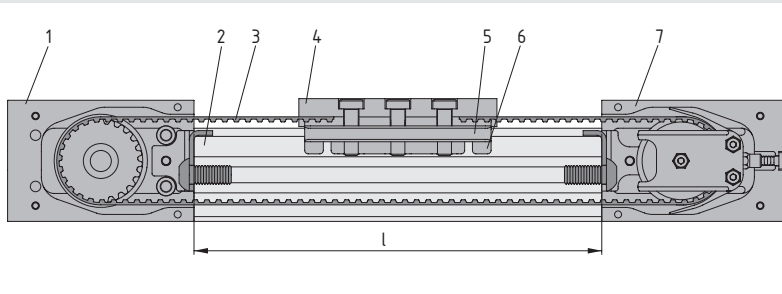

- 1 Drive Unit GSF 8 40 R10
- 2 Profile X 8 40x40 1N
- 3 Timing Belt R10 T5
- 4 Slide plate*
- 5 Sliding shoe*
- 6 Slide*
- 7 Timing-Belt Reverse Unit GSF 8 40 R10

*(4, 5, 6 = Slide Set GSF 8 80x40)

Belt length
 $L = 2 \times l + 210 \text{ mm}$

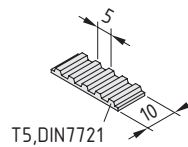

Timing Belt R10 T5

With integrated steel wires
 Perm. load 300 N
 $K = 75 \text{ N}$
 $m = 23 \text{ g/m}$

black, cut-off max. 50 m

0.0.400.04

black, 1 roll length 50 m

0.0.400.11

Design

Simplified method for determining the maximum permissible load for the T-Slot Slider of a GSF:

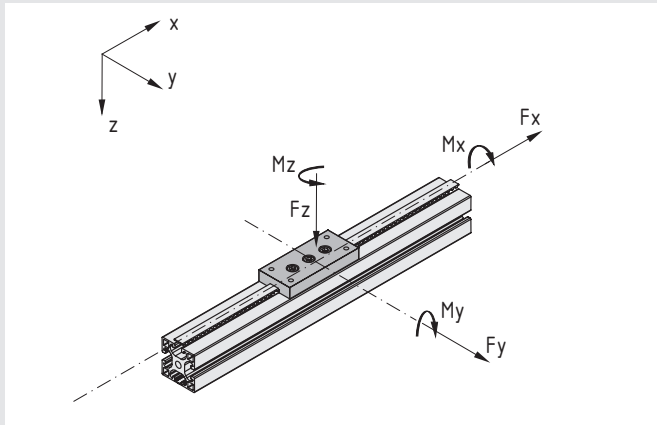

Run length under max. load: 1000 km
Max. Speed: 1 m/s

GSF	$M_{x \max}$ [Nm]	$M_{y \max}$ [Nm]	$M_{z \max}$ [Nm]	$F_{y \max}$ [N]	$F_{z \max}$ [N]
	0.4	2	1.25	25	50

The following applies for combined loads:

$$\frac{|M_x|}{M_{x \max}} + \frac{|M_y|}{M_{y \max}} + \frac{|M_z|}{M_{z \max}} + \frac{|F_y|}{F_{y \max}} + \frac{|F_z|}{F_{z \max}} \leq 1$$

Description of timing-belt drive:

Ball-bearing mounted timing pulley
Effective radius: $r = 18.3 \text{ mm}$
Pitch: $p = 5 \text{ mm}$
Number of teeth: $z = 23$
Max. drive power $M_A = 3 \text{ Nm}$

Frictional moment when running light:

$M_R = 0.1 \text{ Nm}$ Ambient conditions:
Storage temperature $-20 \text{ }^\circ\text{C}$ to $+70 \text{ }^\circ\text{C}$
Relative humidity 5 % to 85 %

Linear Unit GSF 8 40 R10 is intended as a permanent fixture to be used in an area that is protected from the weather.

The area should be free from mould and fungus and show no traces of rodents or other pests.

Do not install or use in close proximity to industrial plants that produce chemical emissions.

Do not install or use near sources of sand or dust.

Do not install or use in an area that is regularly exposed to high-energy surges such as those caused by presses or heavy machinery, for example.

In case of doubt regarding resistance to certain chemicals such as test oil, alloyed oils, aggressive cleaning substances, solvents or brake fluid, we advise that you consult your specialist representative.

Consult the manufacturer if using in very salty air.

Deflection in the linear axis of the GSF 8 40 R should not exceed 1 mm over an axis of 1000 mm. In scenarios where high demands are placed on the system dynamics, supports should be added every 300 mm to 600 mm. These supports must not affect the Reverse Units.

⚠ When retrofitting to an existing frame, it may be necessary to machine an opening for the belt under certain circumstances (e.g. sliding door)

Assembly

1. Profile machining:

Cut the Line 8 profile to size.

Profile length: $L_{\text{profile}} = 2 \times S + H + 85 \text{ mm}$
 $S =$ safety zone = 27.5 mm
 $H =$ stroke

Tap a thread into the core bore at both ends of the Line 8 profile: M8x25

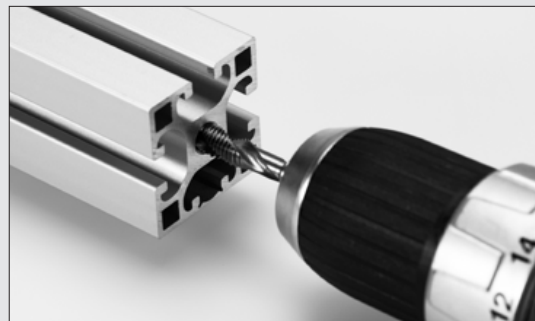

2. Preparing Slide Set GSF 8 80x40:

Press the 3 hexagon nuts ISO 4035-M6 into the slide.

! The outer screws are sufficient to ensure the Timing Belt is clamped in place between the carriage plate and the slide. The hexagon nuts ISO 4035-M6 are used to fasten the carriage plate.

! If one of the screw connections is not to be used, you must leave out the corresponding hexagon nut, as it could otherwise fall into the slide track during operation and cause damage.

Next, slot Slide Set GSF 8 80x40 into the open groove of the Line 8 profile. The carriage plate has not been fitted at this point.

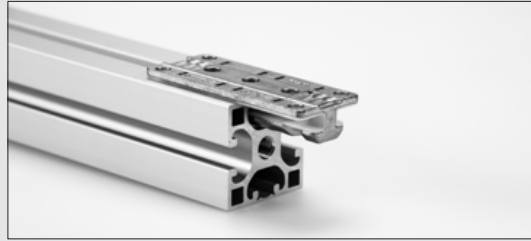
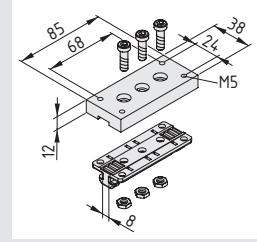

3. Fitting the retaining bracket:

Use one Button-Head Screw ISO 7380-M8x18 each to install the retaining bracket for Timing-Belt Reverse Unit GSF 8 40 R10 and Drive Unit GSF 8 40 R10.

Tightening torque M8x25: 25 Nm.

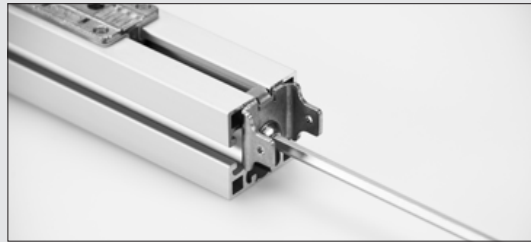

4. Inserting the Timing Belt:

! First cut the Timing Belt to the calculated length then insert it into the groove or cavity of the Line 8 profile. We recommend leaving the Timing Belt a little longer than the calculated length to allow for corrections.

Timing Belt length: $L_B = 2 \times L_{\text{Profile}} + 210 \text{ mm}$

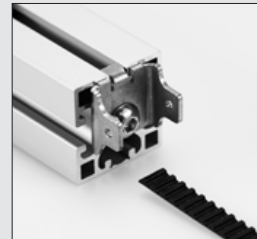
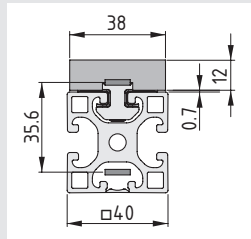

Example: Profile X 8 40x40

5. Fastening the Timing-Belt Reverse Unit and the Drive Unit:

After pushing the Timing Belt through the lower groove of the profile, feed it into the Drive Unit and the Timing-Belt Reverse Unit.

Next, use 2 Hexagon Socket Head Cap Screws DIN 6912-M4x6 each to fasten the Reverse Unit and Drive Unit housings to the retaining bracket.

Tightening torque: $M = 3 \text{ Nm}$

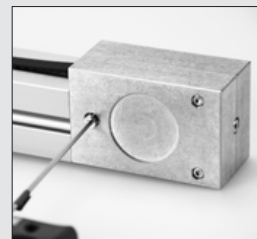

6. Fastening the Timing Belt to Slide Set GSF 8 80x40:

Fit the Timing Belt onto the teeth on Slide Set GSF 8 80x40. Make sure you mesh all the teeth. Next, use the cover plate, the M6 nuts that were inserted previously and the Hexagon Socket Head Cap Screws DIN 6912-M6x20 to clamp the Timing Belt in place. To do this, you must use at least the two outer screws.

⚠ If one of the screw connections is not to be used, you must leave out the corresponding hexagon nut, as it could otherwise fall into the slide track during operation and cause damage.

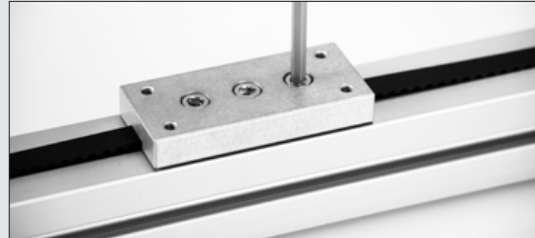
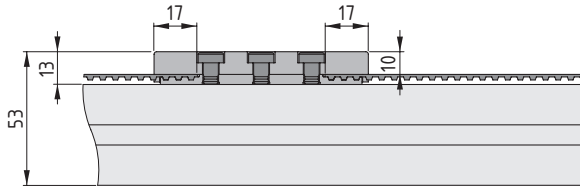

7. Calculating and setting the Timing-Belt tension:

⚠ If the GSF 8 80x40 has been supplied fully preassembled, you will need to adjust the pre-tensioning or check it against the order specifications.

The first step when tightening the Timing Belt is to find the zero point at which the untightened belt has no sag at all and pre-tensioning begins. To do this, use the tensioning screw at the rear of the Timing-Belt Reverse Unit to pull back the movable tensioning axle. The tensioning axle setting required on the Reverse Unit varies according to the operating load of the GSF.

Conventional calculation:

The following applies: $F_{BP} + F_x < F_{Bperm}$

and: $F_{BP} > F_x$

where: $F_x = m \times a + m \times g + F_f$

where: $\Delta L = 2 \times$ tensioning axle setting [mm]

$L_B =$ total length of Timing Belt [mm]

$F_{BP} =$ pretensioning on Timing Belt [N]

$F_{Bperm} =$ permissible force for Timing Belt [N]

$F_x =$ operating load [N]

$F_f =$ frictional force, loss of friction when running light [N] = 5.5 N

$K =$ constant of expansion [N]

$$\Delta L = \frac{L \cdot F_v}{1000 \cdot K}$$

Use the tensioning screw to adjust the movable tensioning axle in the Timing-Belt Reverse Unit. Moving the axle makes the Timing Belt tighter or slacker, adjusting the tensioning axle setting by 1 mm adjusts the Timing Belt by 2 mm. The calculated tensioning axle setting can be checked by various means.

Typical tools include frequency analysis tools, strain gauges and other length measuring devices.

Tip:

You can use markings and a steel ruler to check pre-tensioning.



Connecting the Drive Set GSF 8 40 R10

Drive Set GSF 8 40 can be used to connect any drives to Linear Unit GSF 8. The versatile coupling can be adapted for several different drive shafts and transfers drive torque without play. Hexagon Socket Head Cap Screws DIN 7984 M4x45 are supplied with the Drive Set for this purpose and are screwed through the housing of the Drive Unit and into the Coupling Housing of the Drive Set. Tightening torque: $M = 3 \text{ Nm}$

Machine the drive casing or Adapter Plate according to the requirements of the motor or gearbox you are using and then screw it to the motor or gearbox. Take the Coupling Half that is to be connected to the drive shaft and drill a hole in it to match the drive shaft then connect the Coupling Half and the shaft. The

torques transferred by the clamp connection factor in the maximum mating play for shaft fits: Shaft k6 / hole H7

Force is transferred from the coupling to the drive shaft by means of frictional resistance. The Shaft and the hole in the coupling hub must be degreased and cleaned to ensure the frictional resistance is effective. If the drive shaft requires a rigid connection to the Coupling Half, this must be machined in accordance with specifications of the motor or gearbox manufacturer. Hexagon Socket Head Cap Screws must be secured against working loose.

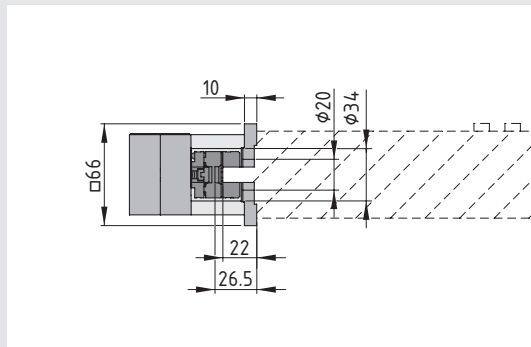
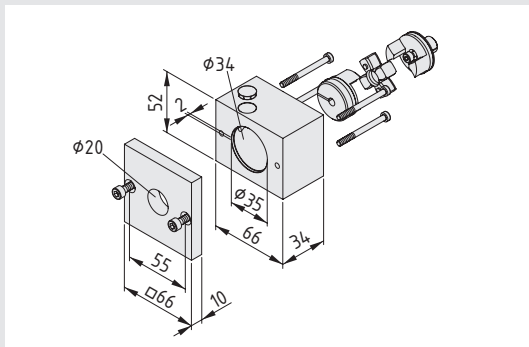

Connection geometry:

Minimum insertion depth for the drive shaft: 22 mm
Maximum insertion depth for the drive shaft: 26,5 mm

Clamping connection between motor shaft and coupling:

Clamping screw: M3
Tightening torque: 1.5 Nm
Bore diameter D[mm] of the motor shaft: D6-D16
Transferable torque M_A : 3 Nm

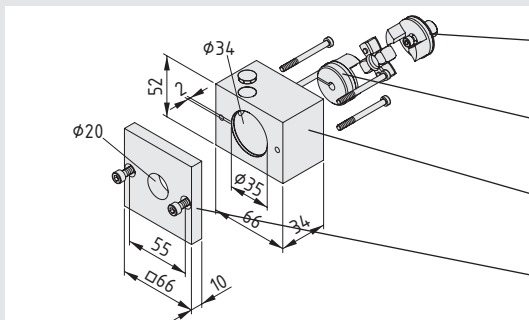
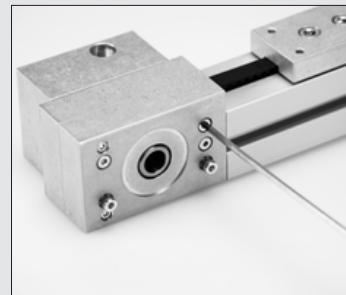

Coupling Half to be connected to the drive Reverse Unit

Coupling Half to be machined, for connecting a drive shaft

Drive casing to be machined, for connecting a gearbox or motor

Connecting Plate to be machined, for connecting a gearbox or motor

The subsequent installation sequence varies according to the circumstances. We advise first slotting the entire coupling onto the drive shaft and fastening the motor to the prepared flange plate or Coupling Housing. Once this has been done, slot the coupling onto the shaft of the GSF 8 40 R10 Reverse Unit. Use a 2.5 A/F Allan key inserted through the holes in the Coupling Housing of the

Drive Set GSF 8 40 to set the necessary clamping force between the coupling and drive shafts. Next, use the caps to cover over the access points to the rotating coupling.

Maintenance

Linear Unit GSF 8 40 R10 requires no maintenance. The plastic in the slide has been optimised for gliding. If the load specifications are observed, the slide will stay within tolerable wear limits for a service life of 1000 km, after which point it will need to be replaced. The degree of wear that occurs during operation depends largely on the conditions of use and should be checked at regular intervals.

Ideal operating conditions:

Ambient temperature: 10°C ... 40°C

Load: < 5%

Stroke velocity: < 1 m/s

The Timing Belt should be inspected every 250 km and replaced if any visible damage, wear or unusual travel noises are observed.

item

item Industrietechnik GmbH
Friedenstrasse 107-109
42699 Solingen
Germany

Phone +49 212 6580 0
Fax +49 212 6580 310

info@item24.com
www.item24.com



You find the Notes on Use and Installation online, in the download section for this product.