

Contents

Symbols, safety	2
General safety information	2
Correct use	3
Improper use	3
Operating parameters	4
Installation	5
Accessories	9
Maintenance	11

Symbols, safety



Important, safety information, recommendation



Maintenance

General safety information

The details and information in the installation guide are provided for the purposes of describing the product and its assembly only. The information does not discharge the user from the obligation to carry out his own assessments and checks. It is important to bear in mind that our products are subject to a natural process of wear and ageing. These notes contain important information that will enable you to use the product safely and appropriately. When sold, rented out or otherwise passed on to another party, this product must be handed over with the installation guide.

When installing, operating and maintaining Linear Unit KRF 8 80x40 ZR, it is important to ensure that all moving elements are secured so that they cannot be switched on and moved unintentionally. Rotating and moving parts can cause serious injury! You must therefore read and follow the safety instructions set out below.

- All work on and with Linear Unit KRF 8 80x40 ZR must be performed with "safety first" in mind.
- Always switch off the drive assembly before you start working on Linear Unit KRF 8 80x40 ZR
- Ensure the drive unit cannot be switched on unintentionally, e.g. by affixing warning notices at the activation point or by removing the fuse from the power supply.
- Do not place your hand within the operating range of moving parts in Linear Unit KRF 8 80x40 ZR when the unit is still switched on.
- Fit guards and covers so that the moving parts of Linear Unit KRF 8 80x40 ZR cannot be touched unintentionally.
- Observe the regulations pertaining to accident prevention and environmental protection that apply in the country and place of work where the product is being used.
- Use only item products that are in perfect working order.
- Failure to use original spare parts will invalidate the product warranty!
- Check the product for obvious defects.
- Use the product only within the performance range described in the technical data.
- Ensure that all the safety equipment associated with the product is present, properly installed and in full working order.
- Do not alter the position of safety equipment, circumvent it or render it ineffective.

Linear Unit KRF 8 80x40 ZR, as described here, corresponds to the state of the art and takes into account the general principles of safety applicable at the time this installation guide was published. Nevertheless, failure to observe the safety instructions and warning notices in this installation guide may result in personal injury and damage to property.

We will assume no liability for any resulting damage or injury. We reserve the right to make technical changes that represent technical advances. Keep these installation notes in a place where they can be easily accessed by all users. Observe the directions contained in the main user guide for the completed machine.

The general safety information applies to the entire lifecycle of the partly completed machine.

1. During transportation

Observe the handling instructions on the packaging. Until it is installed, the product must be stored in its original packaging, protected from moisture and damage. Ensure that moving parts are secured when in transit and cannot cause any damage.

2. During installation

Always deactivate the power to the relevant system part and ensure it is not live before installing the product and/or plugging it in or unplugging it. Ensure the system cannot be switched back on. Lay cables and lines in such a way that they cannot be damaged and do not represent a trip hazard. Avoid areas that pose slip, trip and fall hazards.

3. During start-up

Allow the product to acclimatise for a few hours before starting it up. Ensure that the partly completed machine is securely and safely integrated into the completed machine. Only start up a product that has been installed in full.

4. During operation

Ensure that only persons who have been authorised by the operator have access to the immediate operating environment of the system. This also applies when the system is not in operation. It must not be possible to actuate moving parts unintentionally. During emergencies, malfunctions or other irregularities, deactivate the system and ensure that it cannot be switched back on. Prevent the possibility of persons becoming trapped in the system's hazard zone.

5. During cleaning

Close all openings with suitable protective equipment to ensure that cleaning agents cannot penetrate the system. Do not use aggressive cleaning substances. Do not use a high-pressure cleaner when cleaning the system.

6. During maintenance and servicing work

Carry out the prescribed maintenance work at the intervals stipulated in the user guide. Ensure that no line links, connections or components are removed while the system is live and under pressure. Ensure the system cannot be switched back on.

7. During disposal

Dispose of the product in accordance with the national and international regulations that apply in your country.

Correct use

Linear Unit KRF 8 80x40 ZR is a partly completed machine as defined in the Machinery Directive (2006/42/EC). Linear Unit KRF 8 80x40 ZR must only be used in accordance with the technical data and safety requirements set out in this document. Internal company requirements and the regulations that apply in the country where the product is being used must be observed. You must not make any design modifications to Linear Unit KRF 8 80x40 ZR yourself. We will assume no liability for any resulting damage or injury. You may only install, operate and maintain Linear Unit KRF 8 80x40 ZR if:

- Linear Unit KRF 8 80x40 ZR has been integrated properly and safely into the completed machine,
- You have carefully read and understood the installation guide,
- You are appropriately qualified,
- You are authorised to do so by your company,
- You are using only original equipment from the manufacturer.

Unsafe or inappropriate use of Linear Unit KRF 8 80x40 ZR runs a risk of serious injury through crushing and cuts.

Improper use

Improper use is defined as any use of the product for purposes other than those authorised in the installation guide and under the definition of correct use. We will assume no liability for any resulting damage or injury.

Operating parameters

Eight rollers, arranged play-free in a criss-cross pattern, ensure maximum load-carrying capacity with compact size.

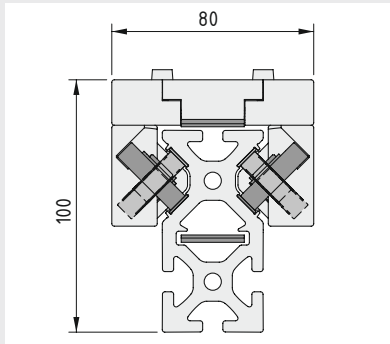

Transmissible drive torque: $M_{Amax} = 23 \text{ Nm}$
 Operating load: $F_{max} = 1000 \text{ N}$
 Max. speed: $v_{max} = 10 \text{ m/s}$
 Max. acceleration: $a_{max} = 10 \text{ m/s}^2$
 System-related frictional moment: $M_{frictional} = 2 \text{ Nm}$
 Effective radius of pulley: $r_w = 23.1 \text{ mm}$

Tightening torque for the screws used:

M3 - 1.5 Nm
 M5 - 6 Nm
 M6 - 10 Nm
 M8 - 25 Nm

The special Timing Belt:

- Gearing type: AT profile, 5 mm pitch
- Belt width: 25 mm +0/-0.5 mm
- Special belt with 0.9 mm steel wires for high positioning accuracy
- Wire strength: 4000 N
- Specific spring rate: $0.998 \times 10^6 \text{ N}$
- Polyamide coating on teeth side, colour: grey/anthracite
- Max. load capacity of Timing Belt: 1000 N limited by the tooth stability of the Timing Belt

⚠ Caution! Timing Belt pretensioning: max. 1‰ of the Timing Belt length

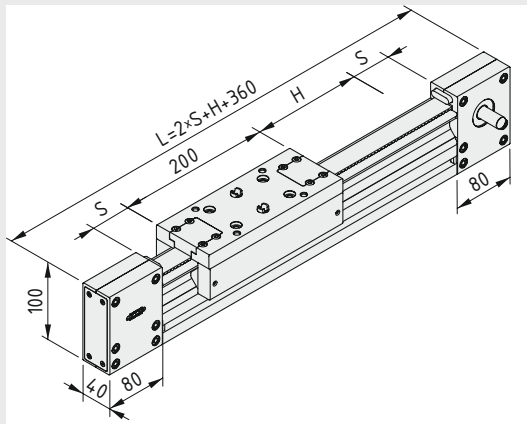

Linear Unit KRF 8 80 x40 ZR
 0.0.641.21

L_{min}	400 mm
S_{min}	20 mm
H_{max}	5,760 mm
m_1 (basic unit)	6 kg
m_2 (per add. mm travel)	4.4 g/mm

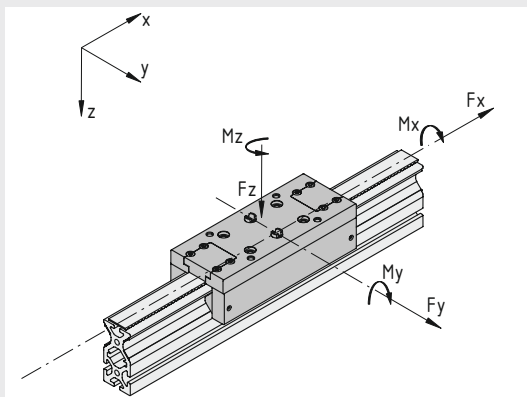

Load Specifications

Simplified method for determining the maximum permissible load for the Roller Guides of a KRF:

KRF	$M_{x,max}$ [Nm]	$M_{y,max}$ [Nm]	$M_{z,max}$ [Nm]	$F_{y,max}$ [N]	$F_{z,max}$ [N]
	50	175	175	2,500	2,500

$$\frac{|M_x|}{M_{x,max}} + \frac{|M_y|}{M_{y,max}} + \frac{|M_z|}{M_{z,max}} + \frac{|F_y|}{F_{y,max}} + \frac{|F_z|}{F_{z,max}} \leq 1$$

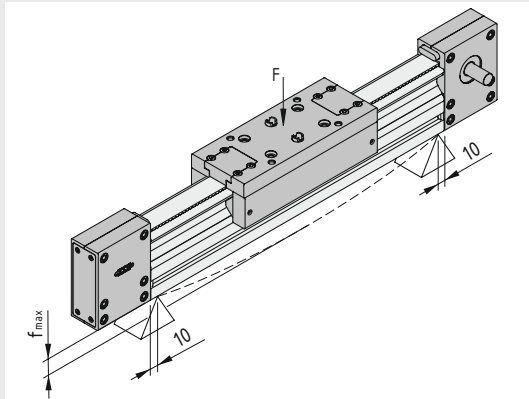

Deflection

The maximum deflection, f_{max} of the system is governed by the dimension of the profile cross-section, the free profile length and the force applied. It should not exceed 1 mm/m. The KRF profile must be given appropriate support if the linearity of movement has to be very precise.

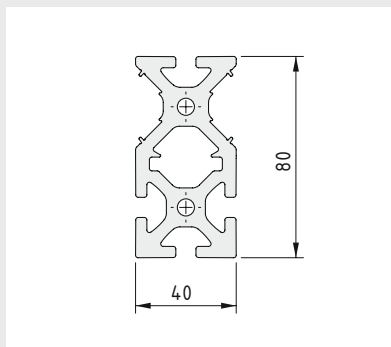

The mass moments of inertia of the profile provide the basis for calculating the deflection:

	Linear Unit KRF 8
I_y	95.66 cm ⁴
I_z	22.05 cm ⁴
I_t	20.06 cm ⁴
W_y	23.80 cm ³
W_z	11.02 cm ³

Installation

- The compact Roller Guide with the best load-to-size ratio of all item drive elements.
- Light, quiet-running rollers arranged in a criss-cross pattern for high speed
- Innovative track technology – hardened steel tracks (50 m steel strip supplied as roll) rigidly connected to the aluminium guide profile
- Solid, machined, rigid sliding carriage with a broad range of attachment options and integrated Timing-Belt clamping mechanism
- Fully usable Profile 8 grooves on three sides of the KRF guide profile ensure unbeatable flexibility for attachment geometries
- Axes sized to requirements, guide length up to max. 6000 mm recommended
- Motors can be adapted using the universal coupling elements in the Drive Set
- Linear Unit KRF is augmented by a range of useful accessories that make it easy to attach carriage constructions and drive modules



1. Preparation – Profile 8 80x40 KRF and steel strip:

- Cut four M8x20 threads into the core bores at both ends of the Profile 8 80x40 KRF.
- Next, insert the steel strips between the mounting ribs provided.
- The steel strips should be approximately 5 mm shorter than the support profile.
- A roller assembly tool is used to secure the steel strips in place.
- Steel strip, hardened, in a 50 m roll: $L_{\text{steel strip}} = L_{\text{profile}} - 5\text{mm}$

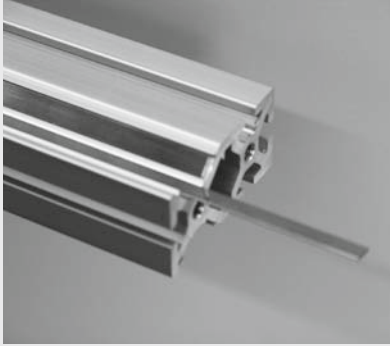

Insert the steel strips into their intended positions.

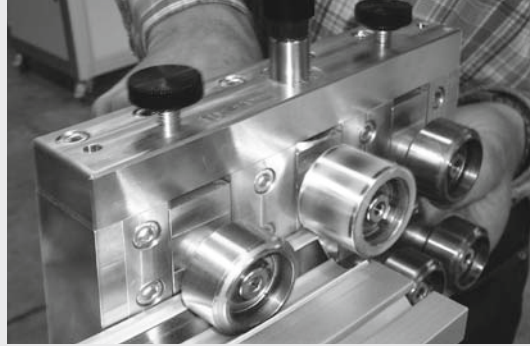

Use the roller assembly tool to bead the aluminium ribs and fix the steel strips in place. Start at the top of the profile then turn the profile and repeat at the bottom.

2. The carriage:

Solid, rigid sliding carriage made from high-quality aluminium alloy with rollers arranged in a criss-cross pattern to absorb loads in the form of radial forces.

- The carriage is supplied as a preassembled construction kit with one side that is screwed firmly in place while the opposite side is a floating bearing end.
- The floating bearing end incorporates two adjusting screws with anti-clockwise fine threads for moving and adjusting the floating bearing end.
- Consequently, the floating bearing is secured by turning clockwise, as usual (turn towards the track on the profile). Turn anti-clockwise to loosen.
- Slot the carriage onto the ready-prepared profile, pushing in the spring-mounted felt pieces a little to stop them getting damaged.
- Tighten the adjustable side (floating bearing end) of the carriage alternately until the carriage is play free.
- Careful adjustment is required to eliminate play when assembling the bearing.
- Next, move the carriage along the entire length of the axis and check that it is free from play.
- Once the carriage is free from play, use the fastening screws to tighten the adjustable carriage side (tightening torque, M8: 25 Nm).
- Retrospective adjustments can be made at any time, as long as the screws are accessible.

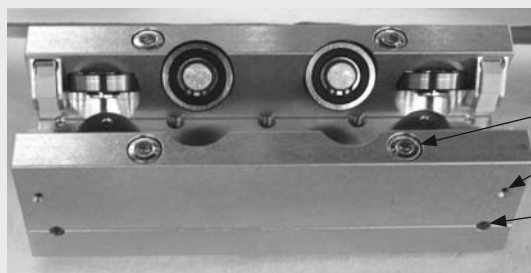

- Fastening screws
- Maintenance openings
- Adjusting screws

3. The Reverse Units:

- The Reverse Unit housings are made from a high-strength aluminium alloy.
- The Reverse Units are supplied as preassembled construction kits.
- Before you can fasten the Reverse Units to the threads that you cut into the core bores of the profile, you will need to remove the covers from the Reverse Units.
- Do not disassemble the Reverse Units any further – fix them to the profile using the built-in fastening screws, which are accessed via an upper bore hole located in each axle and the lower assembly keyholes.
- In the Reverse Unit with integrated Timing Belt tensioning device, the lower fastening screw is accessed through the keyhole in the tensioning screw.
- Fastening screws M8, tightening torque: 25 Nm.
- 5 A/F Allan key.
- The tensioning axle in the Reverse Unit has an adjustment range of 18 mm (= 36 mm elongation in the Timing Belt)
- The current setting of the Reverse Unit is indicated via a gauge on the side of the unit.

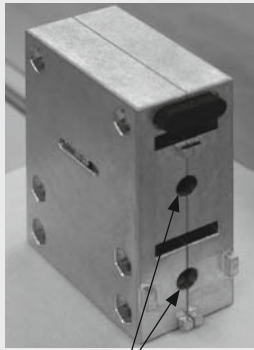

Fastening bores

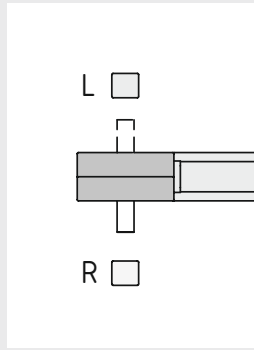

Timing-Belt Drive KRF 8 40 Drive Side

R: Right, 0.0.646.92
L: Left, 0.0.638.97

⚠ Caution! Ensure the Reverse Units are positioned correctly.

- There is **one** Reverse Unit for tensioning the Timing Belt.
- There are **two** Reverse Units for driving the axis.

The position of the drive shaft is different on each of these Reverse Units and must be specified during project engineering.

4. The Timing Belt:

- Timing Belt length: $L_z = 2 \times L_{Profile} + 190$
- Timing Belt pretension: max 1‰
- Special Timing Belt:
 - To enable higher speeds
 - Quiet and smooth running
 - To minimise any polygon effect
- The clamping mechanism for the Timing Belt is integrated into the carriage plate – clamping plates hold the ends of the Timing Belt in the positive locking toothing of the carriage.
- Fit one end of the Timing Belt in place on one side of the carriage, ensuring that all the teeth are engaged.
- Next, screw the Timing Belt clamping device into place (tightening torque, M6: 10 Nm).
- Now feed the other end of the Timing Belt through the Reverse Units and the profile to the opposite end of the carriage.
- The profile does not need to be machined to accommodate the Timing Belt, since a generous amount of space has already been provided.
- To make it easier to feed the Timing Belt through the Reverse Units, first remove the covers on the Reverse Units.
- All the teeth on the Timing Belt should also be engaged in the clamping mechanism at the other end of the carriage. You may need to shorten the Timing Belt.
- Next, screw the second Timing Belt clamping device into place (tightening torque, M6: 10 Nm).



The Timing Belt running through the profile



Timing Belt clamping device

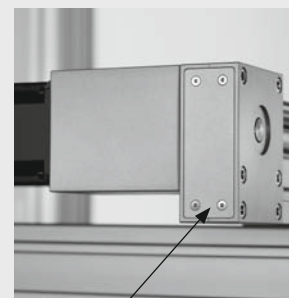

Reverse Unit cover

5. Tightening the Timing Belt:

- A particularly “stiff” Timing Belt will result in low elongation in operation – and therefore high positioning accuracy for Linear Units driven by a Timing Belt.
- The pulley/Timing Belt combination is virtually play free.
- Belt tension is easily adjusted, all adjustment elements are accessible from outside.
- An M10 tensioning screw with a fine thread is located under the cover of the Reverse Unit that incorporates the tensioning device.
- The tensioning mechanics are designed so that turning clockwise tightens the belt. Slotted link mechanics.

- An adjustment range of 18 mm in the tensioning axle corresponds to an elongation of 36 mm in the Timing Belt (1 mm tensioning adjustment equals 2 mm elongation in the Timing Belt).
- Maximum elongation in the Timing Belt = 36 mm (this yields a maximum theoretical Timing Belt length of 36 metres with max. 1‰ elongation).
- Recommended tensioning method:
Make two marks on the Timing Belt (e.g. 1000 mm apart)
Tension the Timing Belt, 1‰ lengths (maximum elongation!)
Check distance (markings) until they are 1001 mm apart.

6. Extending the carriage with Line 8 Profiles

- The preassembled carriage allows you to use the groove of a Line 8 Profile to design a customised superstructure for the carriage.
- For this purpose, two centring sleeves are included with the carriage, which bring the profile groove into alignment, secure it in place and position the profile in the desired orientation.

- Six individually selectable M8 screws can be used to fasten the profile or a purpose-made panel to the carriage.
- Threads in the carriage: M8x18.

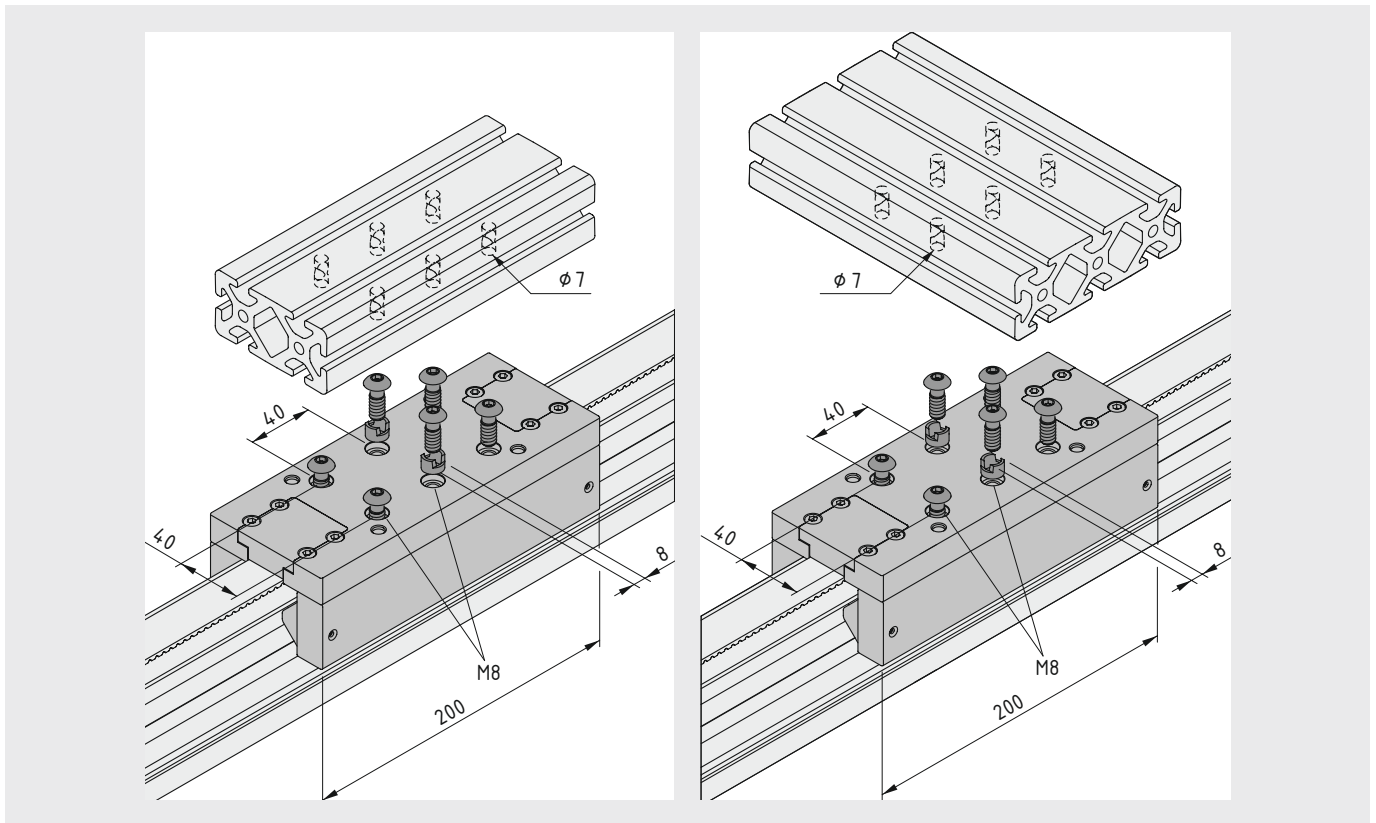

Accessories

The Drive Set

- Drive Set KRF 8 ZR, 0.0.627.46
- Use of high-strength aluminium alloy Coupling Housing with prepared centring piece on the drive Reverse Unit
- Coupling Housing with plenty of area available on the motor side for the customer to machine as required.
- New coupling made from stainless steel
A complete component and therefore entirely play-free

Nominal torque: 60 Nm (⚠ **Caution!** Timing Belt transfers only 23 Nm)
 Axial deviation: 0.2 mm
 Radial deviation: 0.3 mm
 Angular deviation: 1.4°
 Clamping screws: DIN 912 - M6
 Tightening torque: 14.5 Nm

- Up to 50 % deviation, full nominal torque can be transmitted.
- At 100% deviation, 50% of the nominal torque can be transmitted.
- Deviations in between are linear in nature.
- Axial deviations do not affect torque

⚠ This coupling cannot be used with the other Reverse Units because the attachment dimensions of the Reverse Units are far more generously toleranced (die-cast parts). Axial and radial deviations are too great.

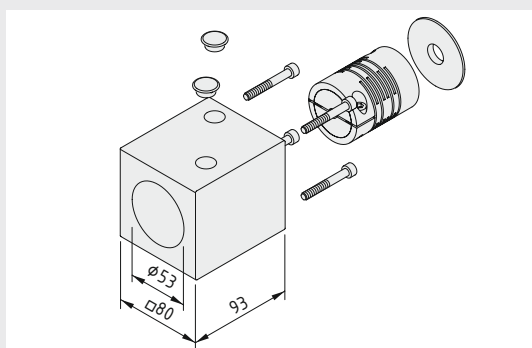
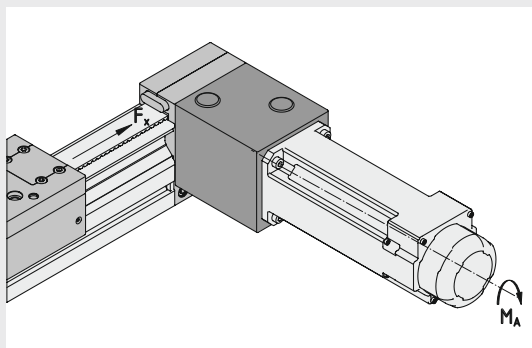

Technical data for the mounting of couplings:

Connection for clamping motor shaft to coupling	KRF 8
Hole diameter D[mm] for motor shaft	8 - 25
Transferable drive torque $M_{A \max}$ [Nm]	23
Permissible operating load of Timing Belt $F_{x \max}$ [N]	1,000
Effective radius of pulley r_w [mm]	23.1
Clamping screw	M6
Tightening torque [Nm]	14.5

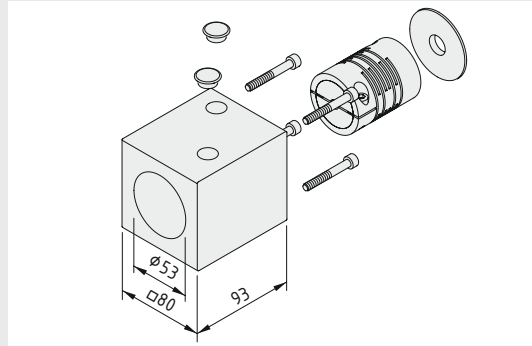
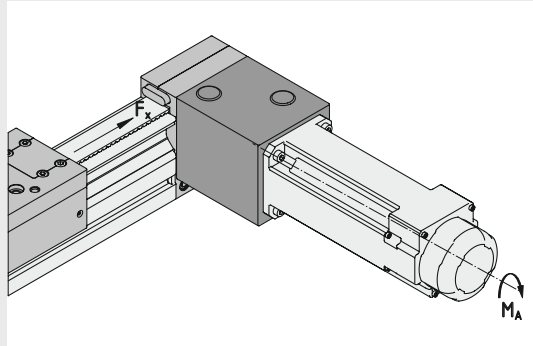
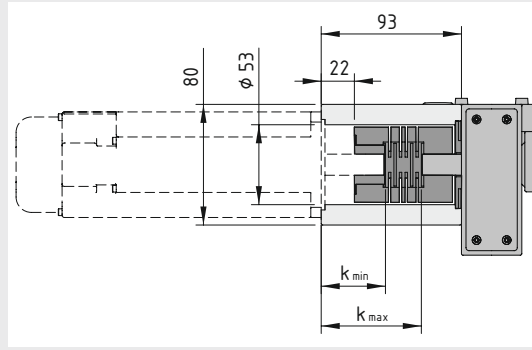
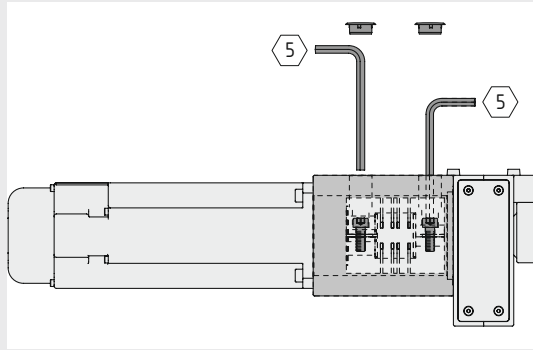

- The housing of the drive Reverse Unit and the Coupling Housing of the Drive Set fit together perfectly thanks to their design and a centring disc. Machine the Coupling Housing of the Drive Set to suit the connection dimensions of the motor or transmission you are using.
- To connect the Drive Set to the drive Reverse Unit, remove 4 of the 6 fastening screws in the drive Reverse Unit and replace them with the longer M6x50 Hexagon Socket Head Cap Screws included with the Drive Set.
- The M6x50 Hexagon Socket Head Cap Screws are driven through the drive Reverse Unit into the Coupling Housing of the Drive Set.
- Tightening torque, M6: 10 Nm
- Bore out the equaliser coupling to match the diameter of the drive shaft of the motor or transmission you are using and clamp it to the drive shaft in line with the mounting dimensions below.
 $k_{\min} = 42 \text{ mm}$
 $k_{\max} = 62 \text{ mm}$
- Next, insert the drive and coupling into the Coupling Housing of the Drive Set and connect them to the drive shaft of the drive Reverse Unit through the Coupling Housing.

Limit-Switch Holder KRF 8

- The Limit-Switch Holder is prepared for fastening to the lower side grooves of Profile 8 80x40 KRF.
- Optimised for Proximity Switch 8
 Proximity Switch 8 1NO, 0.3.001.30 (normally open)
 Proximity Switch 8 1NC, 0.0.600.05 (normally closed)

 Limit-Switch Holder KRF 8 can also be used for position detection on other item linear slides.



Maintenance



- The maintenance openings (page 6) are located on both sides of the preassembled carriage.
- All 4 End Cap and Lubricating Systems are re-oiled through the maintenance openings.
- Minimum stroke, full lubrication: $H_{\min} = 100$ mm.
- Maintenance interval: every 6 months or every 2,500 km
- Fill quantity: approx. 1 ml per End Cap and Lubricating System and maintenance interval (1 ml is equivalent to one pump actuation of the Pressol oil can).



- Recommended oil: Track Oil for Linear Slides (Klüber Oil 4 UH1-460), 0.0.612.75
- Auxiliary tool: Pressol oil can KLE-LR, 0.0.612.74
- The felt pieces are supplied in ready-oiled condition.
- Greases containing solid particles (e.g. graphite and MoS₂ additives) must **not** be used!

item

item Industrietechnik GmbH
Friedenstrasse 107-109
42699 Solingen
Germany

Phone +49 212 6580 0
Fax +49 212 6580 310

info@item24.com
www.item24.com