

Contents

Symbols, safety	2	Assembly	6
General safety information	3	Installation	6
Correct use	4	Calculation	8
Improper use	4	Connecting a drive motor and synchronising the lifting chains	10
Introduction	5	Connecting a drive motor	11
Lifting Door construction	5	Notes	11
Safety considerations	5	Maintenance	11

Symbols, safety

These danger signs warn the user of the possible dangers of the lifting Column. They can be seen on the machine and have the following signification :



Danger

This sign warns particularly of the danger of the lifting door system and its consequences for individuals. It also indicates how to avoid danger and how to operate the Lifting Column correctly.

General safety information

The data and the information contained in the Notes on Use and Installation are intended exclusively for product description and assembly. The information does not release the user from conducting their own assessments and checks. It should be noted that our products are subject to natural wear and tear as well as an aging process.

These Notes on Installation and Use include important information for the safe and appropriate use of the product. In the case of a sale, rent or other transmission of the product, the latter must be accompanied by the Notes on Use and Installation.

During the assembly, operation and maintenance of the lifting door system, it must be ensured that all moving parts are secured against accidental switch-on or moving. Rotating and moving parts can lead to serious injury! Please make sure to read and observe the following safety precautions.

- Any work with or close to the lifting door system must be performed under the motto „safety first“.
- Switch the power supply voltage off before you begin a task close to the lifting door system. Secure the drive unit against accidental switch-on, e.g. by installing signs near the switch or remove the fuse from the power supply.
- Do not reach into the working area of the moving parts of the lifting door system while it is operating.
- Secure the moving parts of the lifting door system against accidental contact by installing protective devices and enclosures.
- Please take note of the applicable regulations for accident prevention and environmental protection in the country of use and the workplace.
- Use item products only in technically perfect condition.
- Non-use of original spare parts leads to the expiry of the warranty!
- Check if the product has obvious defects.
- Use the product exclusively within the range of performance described in the technical data.
- Make sure all the safety devices belonging to the product are available, suitably installed and fully functional.
- You are not allowed to change the position of, avoid or disable safety devices.

The lifting door system described here corresponds to the state-of-the-art and respects the general principles of safety at the date of printing of the present Notes on Use and Installation. Nonetheless, the hazard for personal injury and damage to property remains when the fundamental safety instructions and warning notices mentioned in the present Notes on Use and Installation are not observed.

We accept no liability for any damage that may arise from them. In the interest of further development, we reserve ourselves the right to technical changes. Keep the present Notes on Use and Installation readily accessible to all users. Please take notice of the superordinate instructions for use of the complete machinery or equipment.

The general hazard warning refers to the whole life cycle of the partly completed machinery.

1. Transport

Please note the transport instructions on the packaging. Make sure to leave the product in the original packaging and protect it from humidity and damage until assembly. Please note that moving parts are fixed and can cause no damage during transport.

2. Assembly

Always switch the relevant system component off-circuit before you assemble the product or plug/unplug it. Secure the system against re-starting. Lay the cables and conducts so that they cannot be damaged and nobody can trip over them. Avoid places with risk of slipping, tripping or falling.

3. Putting into service

Let the product acclimatise for some hours before putting it into service. Make sure the partly completed machinery is tightly and safely integrated to the complete machinery. Only put fully installed products into service.

4. During operation

Allow the access to the direct operational area of the system only to people authorised by the operator. This also applies for downtimes of the system. Moving parts must not be accidentally actuated. In case of emergency, error or other irregularities, switch off the system and secure it against restarting. Make sure people cannot be shut in the system's danger zone.

5. Cleaning

Close all openings with appropriate protective devices so that no detergent can enter the system. Use no aggressive detergents. Do not use a high-pressure cleaner for the cleaning.

6. Putting into service and maintenance

Perform the required maintenance work in the time intervals described in the operating instructions. Make sure no connection line, connection or component is released until the system is under pressure and tension. Secure the system against restarting.

7. Disposal

Dispose of the product according to the national and international provisions of your country.

Correct use

The lifting door system is a product in accordance with the Machinery Directive 2006/42/EC (partly completed machinery). The lifting door system can only be used in accordance with the technical data and safety regulations of the present documentation. The internal rules and guidelines of the country of use must be respected. Unauthorised structural changes to the lifting door system are not permitted. We accept no liability for any damage that may arise from them.

You are authorised to assemble, operate and maintain the lifting door system only if:

- The lifting door system has been integrated to the complete machinery according to the intended applications and safety requirements.
- You have read the Notes on Use and Installation carefully and understood them.
- You are qualified.
- You have the authorisation of your company.
- You exclusively use the original accessories of the manufacturer.

In case of unsafe and inappropriate operation of the lifting door system, there is a danger of serious injury from crush and shear points.

Improper use

The inappropriate use refers to applications differing from the use authorised by the Notes on Use and Installation and the appropriate use. We accept no liability for any damage that may arise.

Introduction

A modular Lifting Door System for building Lifting Doors for use in Enclosure & Guard Systems and which are to be raised and lowered either manually or using a motor.

Lifting Door construction

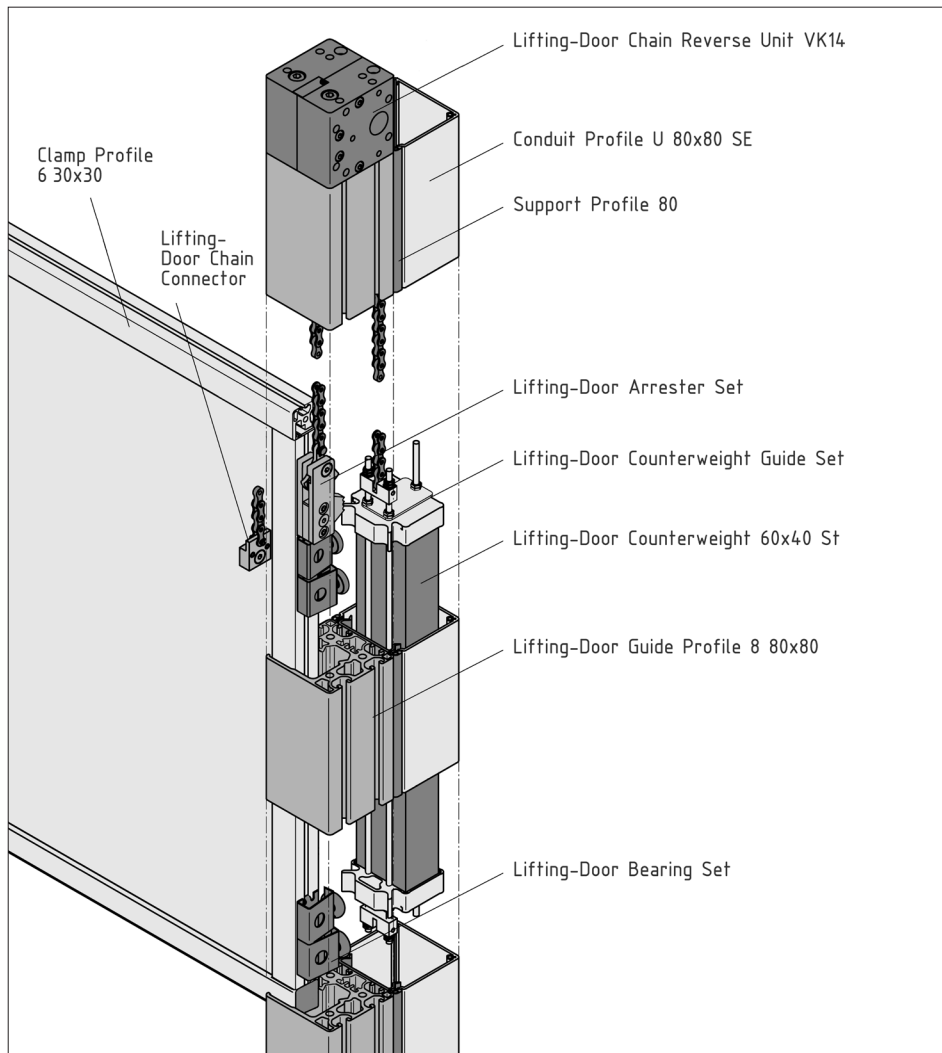

Safety considerations

- During design, safety considerations have been given a particularly high priority:
- At a basic level, two independent, parallel chains provide a high degree of safety.
 - The moving parts are contained within enclosed conduits.
 - The Lifting Door can be fitted with an Arrester Set to prevent injury if a chain breaks and the door drops suddenly.
 - Shock Absorbers can be fitted at the ends of the guide tracks.
 - A Buffer Strip or safety cut-off strip can be fitted in either the upper or lower vertical profile groove of the door frame.

Assembly

There are two alternative Chain Reverse Units available: As a simple counterweight for manually operated doors, use Chain Reverse Unit E; for electrically powered doors, use variant VK14. This variant allows the two chains on a Lifting Door to be synchronised.

The Counterweights are accessible subsequently and can be adjusted.

The elastic guides of the ball-bearing mounted door frame compensate for awkward frame sizes and unfavourable guide set-ups. They are self-adjusting, low-noise, tolerance-compensating constructions.

There are interfaces on the Lifting Door Guide Profiles and Chain Reverse Unit for universal, system-compatible attachments for Enclosure & Guard Systems.

Installation

Installation is simplified by the use of preassembled modules.

Preparation:

- Cut the Lifting Door Guide Profile 8 80x80 and Clamp Profile 6 30x30 to the correct length.



Note:

We recommend running the horizontal Profiles for the door frame (Clamp Profile 6 30x30) straight through for the full length.

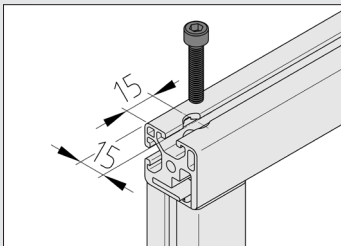

Drill the Clamp Profiles as required:
horizontally - Countersink DIN74-km6
vertically - Thread M6x15 in core bore

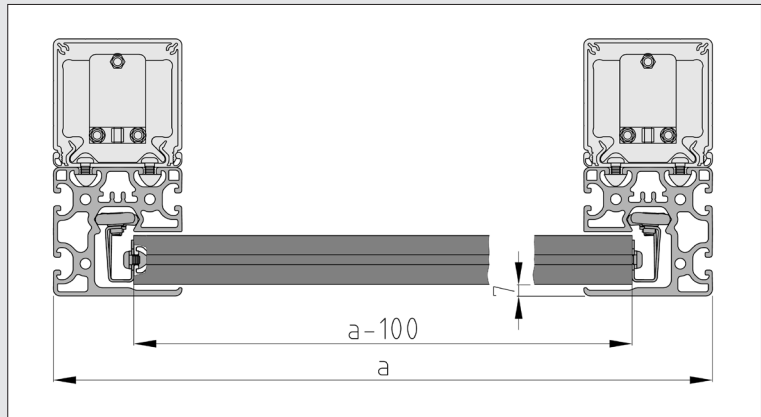

- The vertical Profiles making up the door frame (Clamp Profile 6 30x30) require an additional through hole ($\varnothing 6$ mm; 23 mm deep) for preventing the chain connector guide from slipping subsequently.

- The two Support Profiles 80 which guide the Counterweights are then cut to length (length equivalent to Lifting Door Guide Profile 8 80x80) and require through holes for fixing them to Lifting Door Guide Profile 8 80x80.

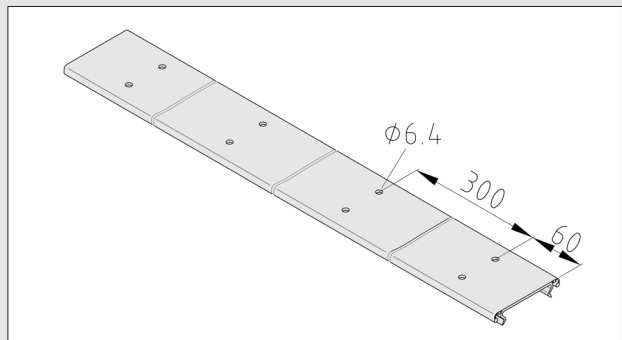
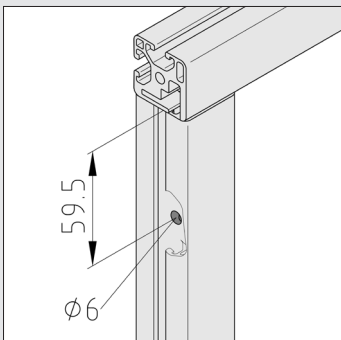

- Machining the Lifting Door Guide Profiles 8 80x80:



Round off the entrance to the V-guides on the upper side of the profile to prevent damage to the pretensioned Rollers when the Lifting Door is slotted in place later.

- Depending on the Lifting Door Chain Reverse Units used (type VK14 or E), it will be necessary to tap the core holes of the Lifting Door Guide Profiles 8 80x80 with an M8 thread (20 mm deep).

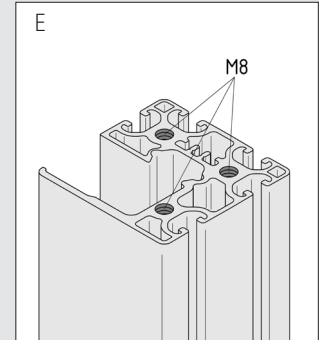
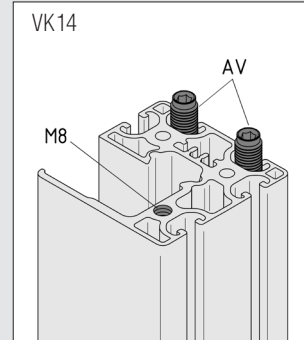
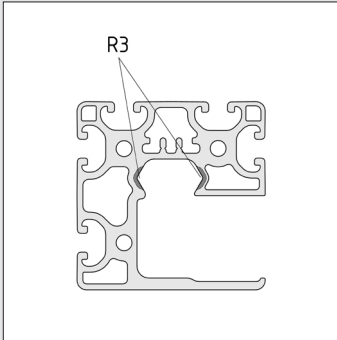

- Assemble the Lifting Door Frame.

Lifting-Door Bearing Sets and Chain Connectors or Arrester Sets are screwed to the outer sides, where the longer screw is screwed through the through hole in the vertical door frame profile to ensure the components cannot slip.

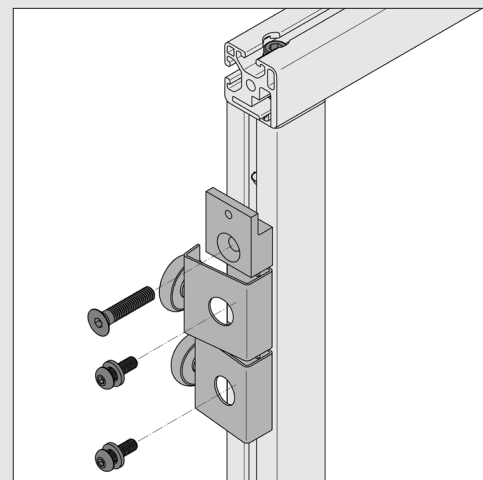
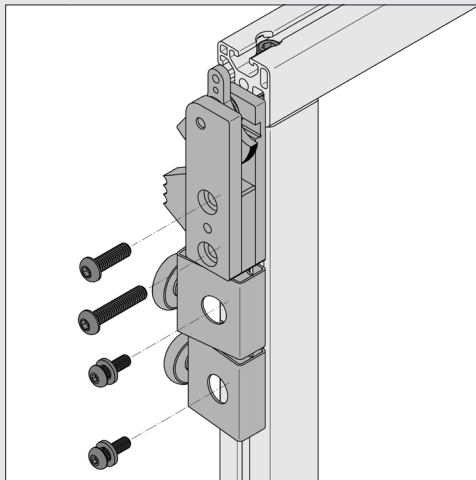

- Any other additional components (e.g. handles, cut-off strips etc.) are attached to the door frame.

Calculation

- Once it has been fully assembled, the door must be weighed to ensure the Counterweights are matched to the door weight.
- Determining the lengths of the two Lifting Door Counterweights:

Length of one Lifting-Door Counterweight 60x40 St (L_G):

$$L_G [\text{mm}] = (\text{mass of the fully assembled door}) [\text{kg}] \times 26 [\text{mm/kg}] - 11 [\text{mm}]$$

s = stroke [mm]

h_1 = door frame height [mm]

h_2 = residual height [mm]

L_G = length of Lifting Door Counterweight [mm]

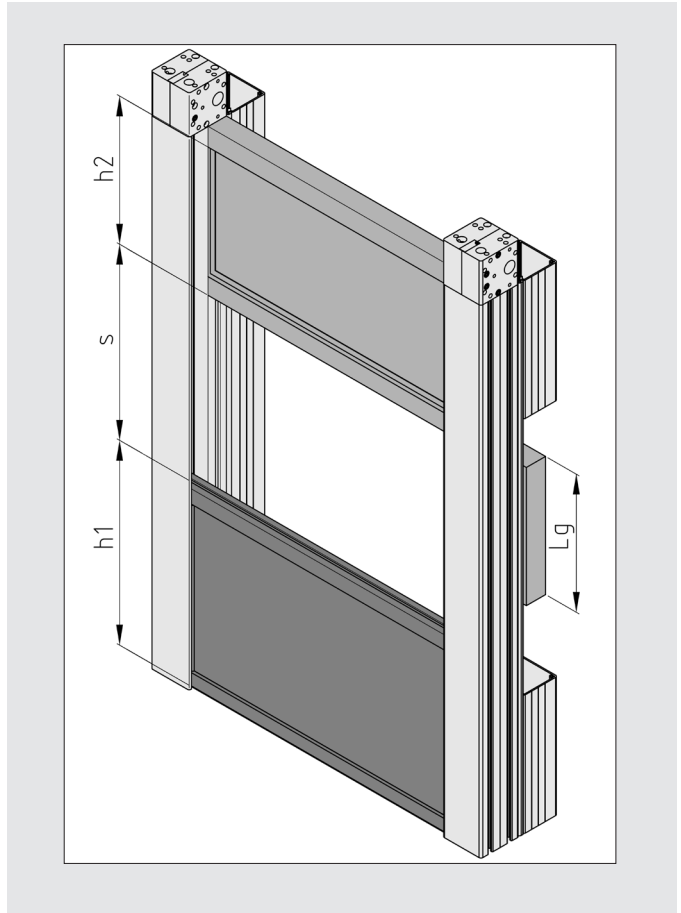

- Determining the length of chain required (L_K):

$$L_K = s + h_1 / 2 + 2 \times h_2 - L_G / 2 + X$$

$X = 165 \text{ mm}$ if connected to Lifting Door Arrester Set (c)

$X = 229 \text{ mm}$ if connected to Lifting Door Chain Connector (b)

The length of the chain as calculated may have to be adapted to suit the exact conditions prevailing at the site.

The Chain has to be split in such a way that the link attached to the Lifting-Door Counterweight Guide Set (a) is an internal link section while that attached to the Chain Connector (b) or Arrester Set (c) consists of two outer link plates. The holes in the outer link plates must not be damaged when the chain is separated.



Assembly is made easier, ergonomically speaking, if the door is lying flat on the workbench with the front surface facing down.

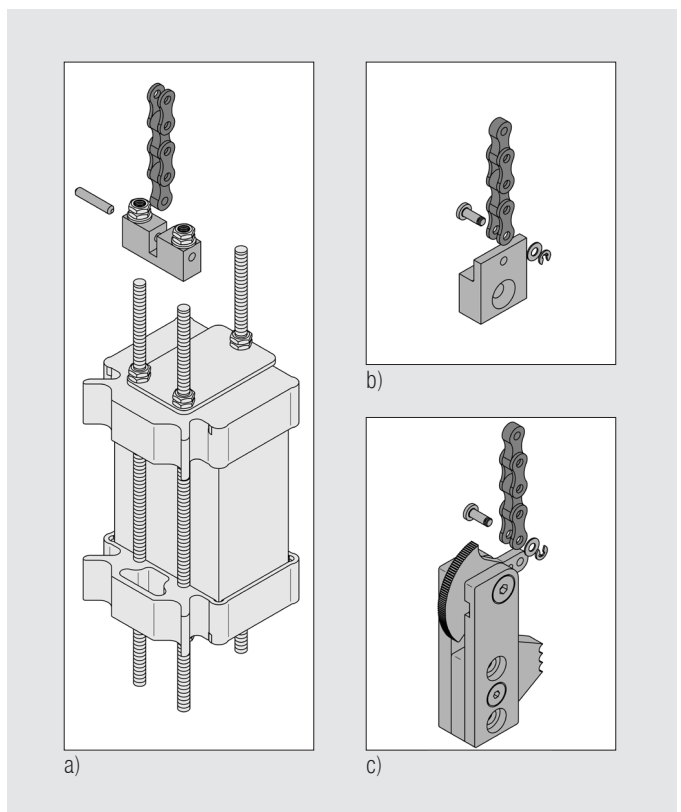

- Screw the machined Support Profiles 80 onto the Lifting Door Guide Profile 8 80x80.
- Attach the Chain to the corresponding points on the Lifting Door Chain Connector or Lifting-Door Arrester Set, and slide the door into the Lifting Door Guide Profiles. (If the Lifting-Door Arrester Set is to be used, it is important to keep the chain taut to enable the door to be inserted).



Note: If assembly is performed vertically, the door must now be fixed to prevent it falling (e.g. using a screw clamp).

- The Lifting Door Counterweight St 60x40 is connected to the Lifting-Door Counterweight Guide Set.

The threaded rods are cut to length, allowing an overlength of 128 mm longer than the Counterweights. The plastic guides are attached to the ends of the Counterweights as caps, screwed to the holding plate and threaded rods and fixed with a locknut. Allow an additional length of approx. 60 mm at both ends of the threaded rods to allow for weight compensation and changes of position.

- Insert the prepared counterweight sets and the attached Counterweight St into Support Profile 80 on both sides.



Note: If the Lifting Door Guide Profiles are vertical during assembly, the Counterweights will have to be clamped to prevent them falling (e.g. with a screw clamp).

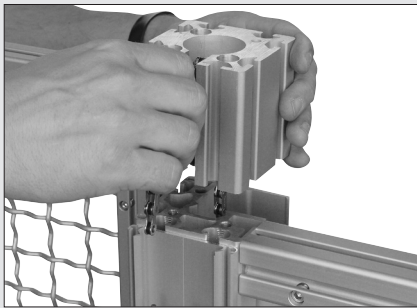
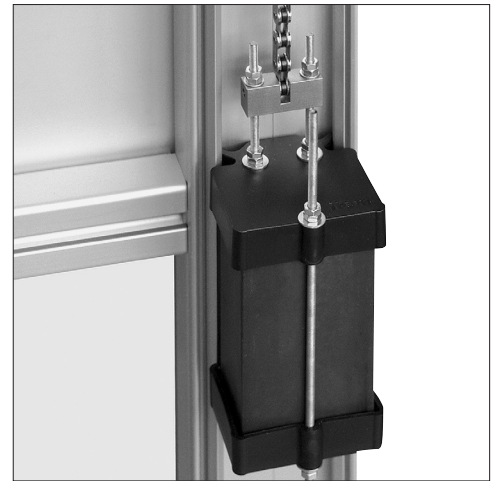

The chain is then passed through the Reverse Units, which are still loose, to the Counterweights.

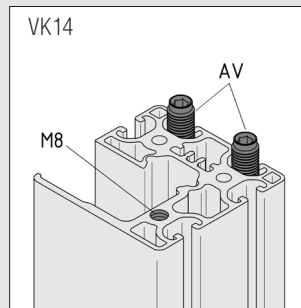

Screw the Lifting Door Chain Reverse Units VK14 to the prepared Lifting Door Guide Profile, at the front, insert one M8x80 screw in the core bore of the Profile, at the rear, screw Hexagon Socket Head Cap Screws M6x90 into the grooves (with Automatic Fastening Sets 8, tapped).

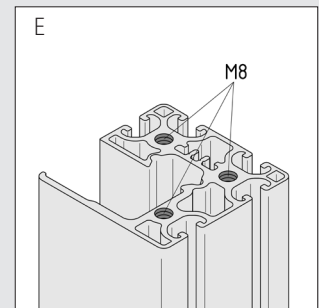

If Lifting Door Chain Reverse Units E are used, attach them to the Lifting Door Guide Profile 8 80x80 using the three Hexagon Socket Head Cap Screws M8x80 supplied in the core holes (tapped to M8).

- Attach the Chains to the Chain Connectors on the Lifting Door Counterweight Guide Set.



Before the Lifting Door assembly is raised and integrated in the Guard Unit, it is essential to fix the moving parts of the Lifting Door to prevent them falling (e.g. use screw clamps).

- The Lifting Door can now be integrated in the Enclosure & Guard System using item system components (L-Based Adjustable Feet, Base Plates, Flat Brackets, Fastening Elements for attaching to profiles).
- Test run the Lifting Door to ensure the running characteristics and clearances of the construction are correct.
- The door and counterweight should be in equilibrium so that the door can be held at any required position. The state of equilibrium can be adjusted accurately since the Counterweight is freely accessible from the rear of the door.

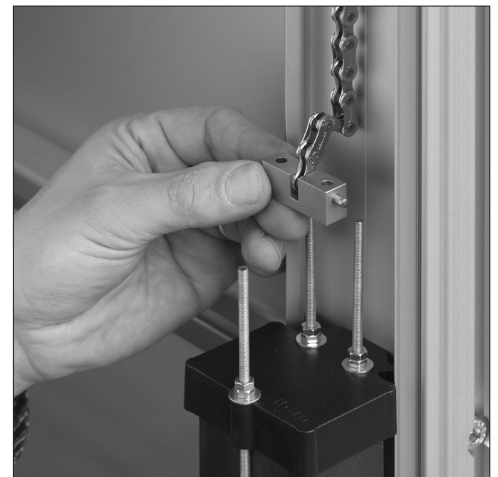

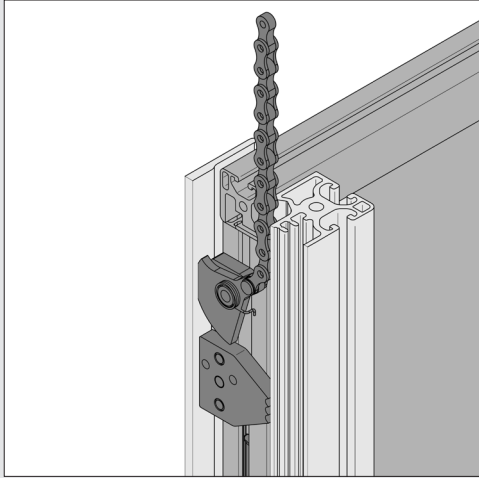

If the Arrester has triggered during assembly, it can be released by tensioning the chain again (by pushing the door up and pulling on the chain).



A Conduit Profile U 80x80 (S)E is used to close off the Counterweight Guides and protect them against inadvertent contact and tampering.

Connecting a drive motor and synchronising the lifting chains

The lifting chains can be synchronised by means of a Synchroniser Shaft between two Chain Reverse Units VK14:

1. Lifting Door Chain Reverse Unit VK14	0.0.485.18
2. Connecting Shaft VK14 R25/WG	0.0.463.15
3. Synchroniser Shaft Equaliser Coupling VK14	0.0.472.28
4. Connecting Shaft U-WG	0.0.408.21
5. Synchronising Shaft Profile VK14	0.0.463.57
6. Connecting Shaft VK14 R25/WG	0.0.463.15
7. Lifting Door Chain Reverse Unit VK14	0.0.485.18

Ensure that the Connecting Shaft VK14 R25/WG is inserted well into the Reverse Unit so that only 30 mm remains accessible for attaching to other components (the catalogue recommends 40 mm). However, this amount is sufficient since the torque to be transmitted is relatively low.



Note:
Synchronising the lifting chains can result in a slight delay in the release of the Lifting Door gravity brake.

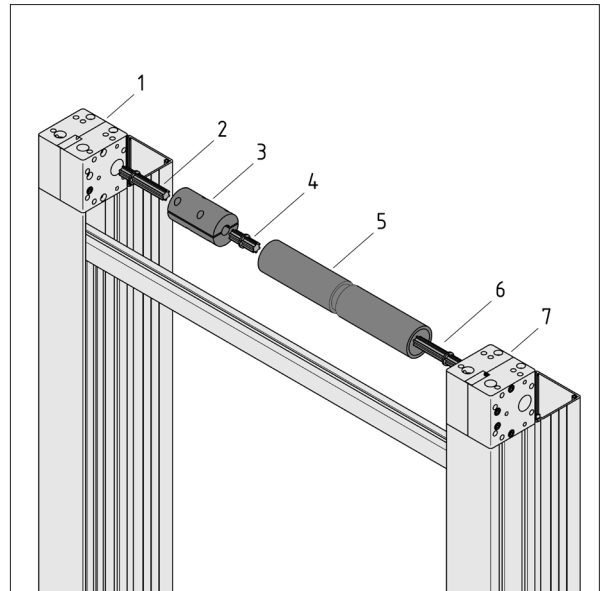

Connecting a drive motor

Electrical motors are connected using mechanical Drive Elements via the Lifting Door Chain Reverse Unit VK14. This Unit is supplied ex works with the required Connection Processing.

To connect a motor, the following system components will be required:

- Coupling Housing 8 D30 (0.0.463.23) or Coupling Housing 8 D55 (0.0.463.22)
- Coupling Half D30 VK14 (0.0.337.67) or Coupling Half D55 VK14 (0.0.337.66)
- Shaft Section VK14 (0.0.337.05)
- Coupling Adapter Plate D30/D55 Universal 80x80 (0.0.463.10) including machining to match the geometry of the motor flange

If a motor is used, we recommend synchronising the Chains with a Synchroniser Shaft. The motor can be attached to any of the Reverse Units on the Lifting Door and can face inwards or outwards.



If the motor is to drive the Lifting Door from below, it will be necessary to fit an "endless" chain to the Lifting Door at least on one side. If the motor is fitted with a suitable brake, the Counterweights can be discarded.



Notes

Customers are reminded that it is necessary to observe regulations relating to minimum spacing and distances between the Lifting Door and other components in the machine installation. When designing the installation, bear in mind that there may be regulations governing the kind of panel elements used (e.g. with regard to impact resistance). In order not to compromise the equilibrium state of the door and the Counterweight itself, ensure the counterweight is adjusted to compensate for any components added to the Lifting Door.

The Lifting Door must be exactly aligned both vertically and horizontally.

Subsequent machining of the Lifting Door Guide Profile 8 80x80 is only allowed if steps are taken to prevent chips and swarf finding their way into the functional components or guide tracks of the Profile. When attaching additional Profiles and modules, use only non-machining fastening technology (e.g. Universal Fastening Set or Angle Brackets).

Maintenance

If the chain or Lifting Door Chain Reverse Unit, the Counterweights or the Lifting Door Bearing Set make too much noise, check the components and, if necessary, replace any worn parts in the interests of safety.

item shall not be liable for damage caused by faulty installation or improper maintenance or handling of the Lifting-Door-System!

item

item Industrietechnik GmbH
Friedenstrasse 107-109
42699 Solingen
Germany

Phone +49 212 6580 0
Fax +49 212 6580 310

info@item.info
www.item.info